

# 1064nm Nd:YAG q-switched picosecond laser MO Microchip laser system



## DESCRIPTION

1064nm laser is one of the most common laser among Crylink's products of solid state laser. Unlike other lasers, 1064nm laser beam is directly emitted from the Nd:YAG crystal. Q-switched crystal helps our laser to emit picosecond output light beam. Either the one with single longitudinal mode or the one with fundamental mode can be chosen in Crylink.

Crylink provides absolute high quality 1064 nm laser. Our 1064nm laser contains high average power, up to 100mW. And it has high pulse repetition frequency, up to 50kHz. At the same time, our 1064nm laser has smaller size and lower power consumption by microchip laser technology.

Our 1064nm laser can be used in most military, civil and scientific research fields. In industry, it can be used in micromachining. In cosmetology, it can be used in picosecond laser tattoo removal machine. Besides, it can also be used in laser ultrasound, laser induced breakdown spectroscopy, etc.

## FEATURES

- Pulse width < 1ns
- The repetition frequency is adjustable from 1 to 200Hz
- The laser energy is adjustable on the machine
- Optical trigger output signal jitter < 100ps
- Fully sealed design, high reliability
- Plug and play, including upper computer software

## APPLICATIONS

- Laser engraving
- Laser photoluminescence
- Laser capture micro-cutting
- Raman spectroscopy detection
- Laser induced breakdown spectrum
- Laser remote sensing

OUTLINE SIZE(mm)

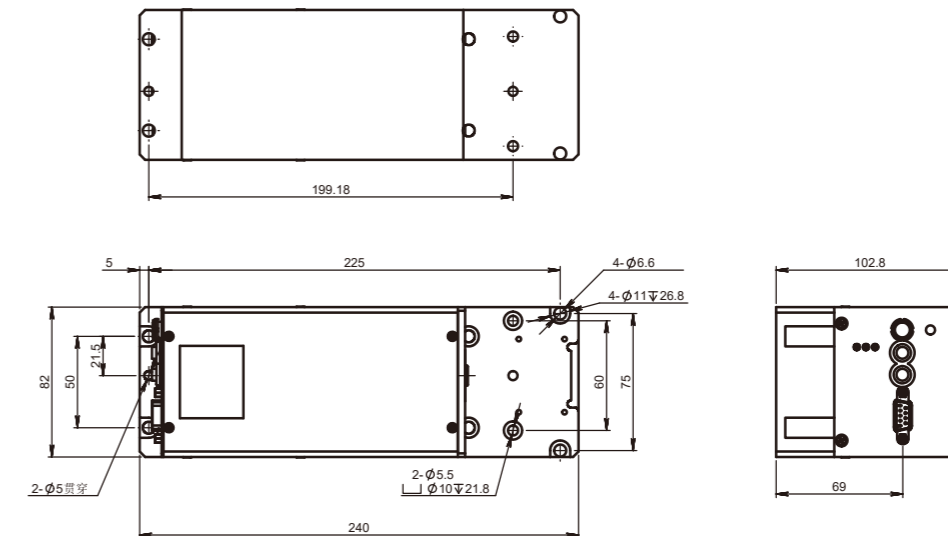

Space output size diagram

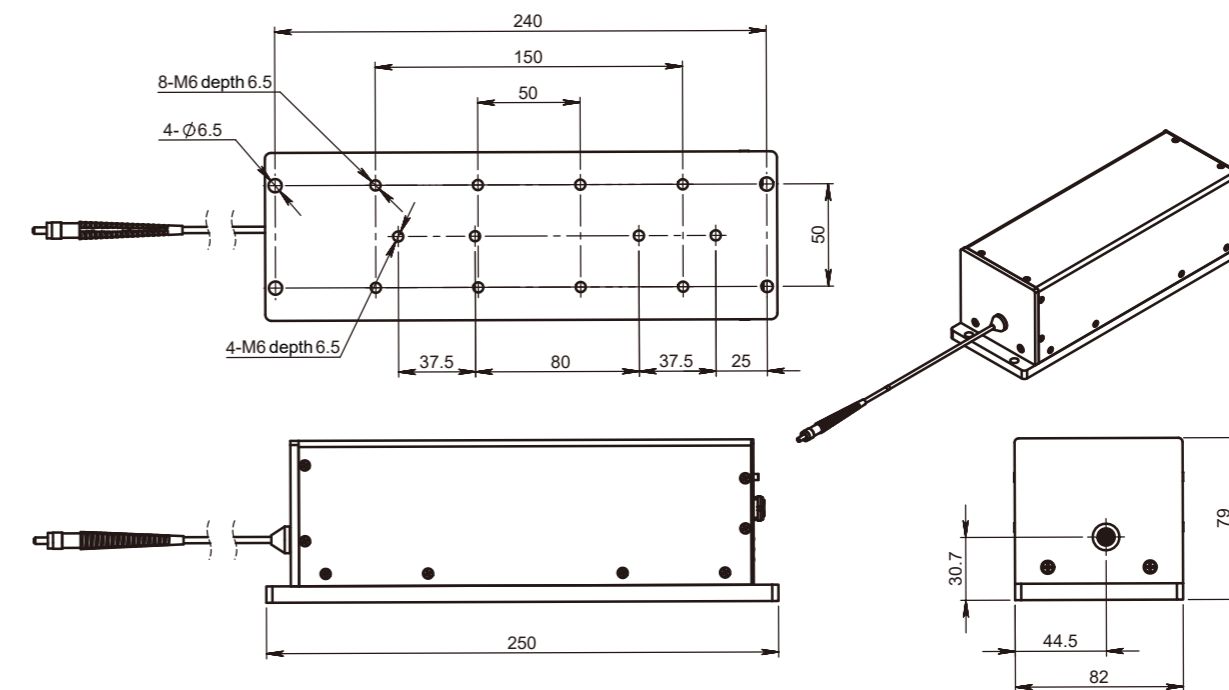

Optical fiber output size diagram



## PARAMETERS

Optical parameter	Model	CL1064-200Hz-60/50μJ-MO004
	Wavelength (nm)	1064
	Repetition frequency (Hz)	1-200
	Maximum output energy of space beam (μJ)	60
	Fiber Coupling Maximum Output Energy (μJ)	50
	Pulse width (ns)	≤1
	Energy Stability(rms)	≤3%
	Energy Regulation Step Accuracy	≤1%
	Beam mode (spatial beam output)	TEM <sub>00</sub>
	Full-angle divergence angle Typ. (Mrad) level @1/e <sup>2</sup>	≤2
	Full-angle divergence angle Typ. (Mrad)Vertical @1/e <sup>2</sup>	≤2
	Polarization characteristics	≥100:1
	Fiber parameters (fiber coupled output optional)	200μm/0.22NA
System parameters	Power input	24V DC
	Modulation input	TTL0-5V,SMB connector
	Control interface	RS232
	System Peak Power Consumption (W)	< 20
	System Average Power Consumption (W)	< 10
	Laser size (W × H × L, mm)	82×102.8×240(space)/ 82x79x250(optical fiber)
	Working temperature (°C)	15-35
	Storage temperature (°C)	0-60

1. The supported operating frequency is 16~200Hz in continuous mode and burst mode.
2. Fiber core diameter: 200μm.
3. The power supply adapter is shipped with matching power supply, which can support 90~260VAC power supply input.

