

1064nm Nd:YAG q-switched nanosecond laser MA Microchip laser system

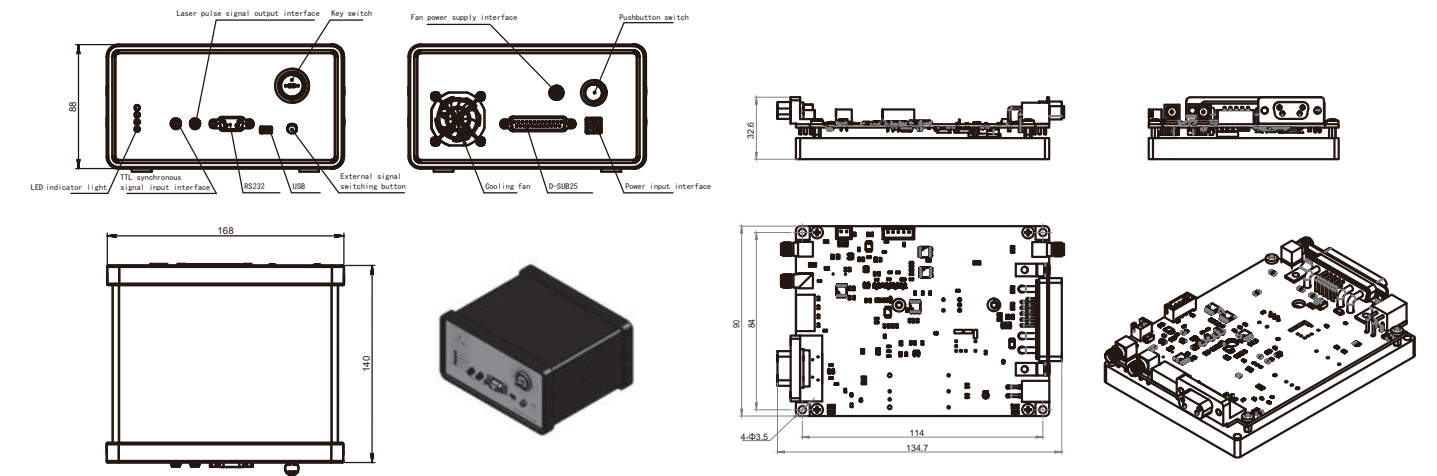

OUTLINE SIZE(mm)



DESCRIPTION

1064nm laser is one of the most common laser among Crylink's products of solid state laser. Unlike other lasers, 1064nm laser beam is directly emitted from the Nd:YAG crystal. Q-switched crystal helps our laser to emit picosecond output light beam. Either the one with single longitudinal mode or the one with fundamental mode can be chosen in Crylink.

ULaser provides absolute high quality 1064 nm laser. Our 1064nm laser contains high average power, up to 100mW. And it has high pulse repetition frequency, up to 50kHz. At the same time, our 1064nm laser has smaller size and lower power consumption by microchip laser technology.

Our 1064nm laser can be used in most military, civil and scientific research fields. In industry, it can be used in micromachining. In cosmetology, it can be used in picosecond laser tattoo removal machine. Besides, it can also be used in laser ultrasound, laser induced breakdown spectroscopy, etc.

FEATURES

- Pulse width up to 1ns
- Pulse energy up to 200μJ
- Repetition frequency up to 20kHz
- Beam mode is TEM₀₀
- Fully sealed design, high reliability

APPLICATIONS

- Lidar
- Laser ranging
- Atmospheric monitoring
- Laser ultrasonic inspection
- Optical metrology
- Laser-induced fluorescence

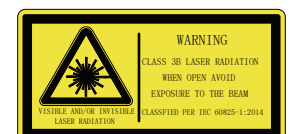
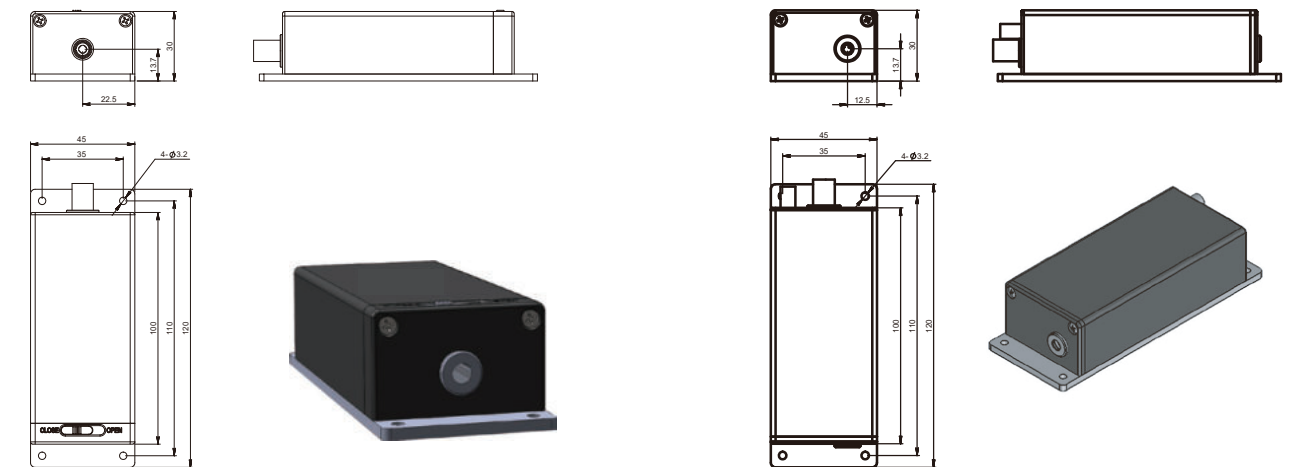

PARAMETERS

Model	CL1064- 1kHz- 120μJ- MA015	CL1064- 2.5kHz- 110μJ- MA016	CL1064- 2.5kHz- 180μJ- MA017	CL1064- 5kHz- 60μJ- MA018	CL1064- 10kHz- 40μJ- MA019	CL1064- 20kHz- 20μJ- MA020
Wavelength (nm)	1064	1064	1064	1064	1064	1064
Repetition frequency (kHz)	1	2.5*	2.5*	5	10	20
Average power (mW)	120	300	500	300	400	400
Output energy (μJ)	120	110	180	60	40	20
Pulse width (ps)	2000	2000	2000	2000	1500	1500
Power stability (8h)	±3%	±3%	±3%	±3%	±3%	±3%
Beam mode	TEM ₀₀	TEM ₀₀	TEM ₀₀	TEM ₀₀	TEM ₀₀	TEM ₀₀
Full-angle divergence angle Typ. (Mrad) level@1/e ²	8	≤3	≤3	8	8	8
Vertical @1/e ²	8	≤3	≤3	8	8	8
Polarization characteristics	>100:1	>100:1	>100:1	>100:1	>100:1	>100:1
Power input	100- 240 VAC, 50/60Hz	100- 240 VAC, 50/60Hz	100- 240 VAC, 50/60Hz	100- 240 VAC, 50/60Hz	100- 240 VAC, 50/60Hz	100- 240 VAC, 50/60Hz
Control interface	RS232, USB	RS232, USB	RS232, USB	RS232, USB	RS232, USB	RS232, USB
System power consumption (W)	≤35	≤20	≤25	≤35	≤35	≤35
Power supply size (W × H × L, mm)	168×88×140	90×32.6×120	90×32.6×120	168×88×140	168×88×140	168×88×140
Laser head size (W × H × L, mm)	45×30×120	45×30×120	45×30×120	45×30×120	45×30×120	45×30×120
Working temperature (°C)	15- 35	15- 35	15- 35	15- 35	15- 35	15- 35
Storage temperature (°C)	0- 60	0- 60	0- 60	0- 60	0- 60	0- 60

1.*The light outlet of the laser head is side outlet. See the mechanical dimension drawing for details

2.Customized internal beam expansion function to meet the requirements of small divergence angle (less than 2mrad)

3. MA016, and MA017 are specially designed for miniaturized weather radar applications. They are small in size, low in power consumption, and can be used in high altitudes, large temperature differences, and other subserve environments. This series accepts dual wavelength laser customization, such as 1064nm&532nm, 1064nm&355nm, or others.

